

**REMOTE CAMERA INSTALLATION KITS
OVERVIEW & INSTALLATION GUIDELINES**

The Cat5 RemoteCam1-S family is offered as a unified electronics platform for cost effective remote Pan Tilt Zoom (PTZ) camera installations. This system, offered in popular kit form, provides a rugged, high quality wall bracket for supporting a camera, a universal power supply, molded color coded cable sets and interface electronics.

Regulated camera power, remote control and S-Video are carried on a **single** standard Cat5 UTP wire for distances up to 300'¹.

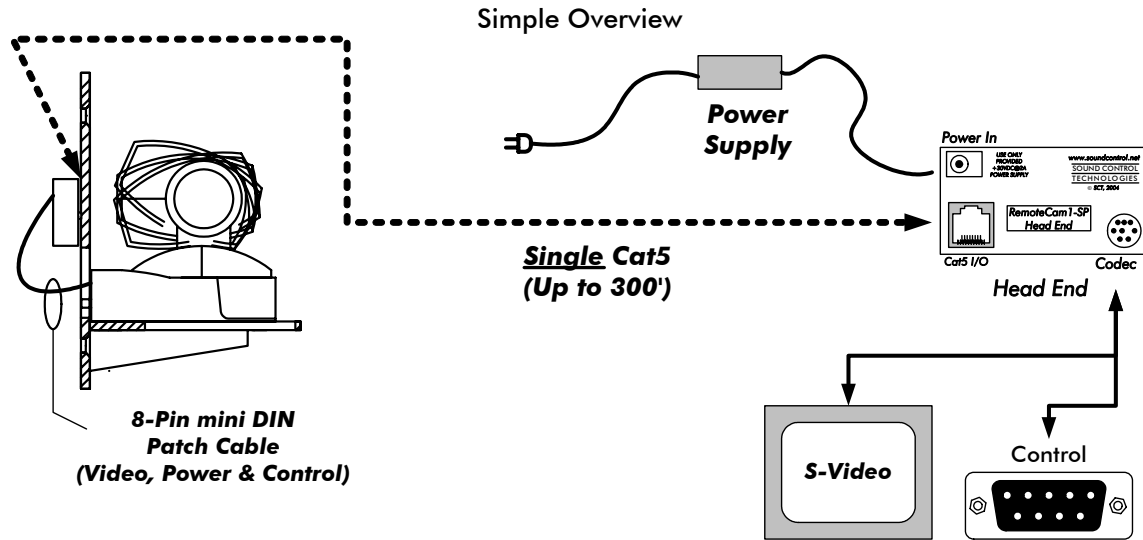

This technique of integrating PTZ cameras reduces installation hardware and labor for each camera position. All hardware and cables are available with these kits to cover the most common video and video conferencing applications for A/V Integrators.

SCT is now offering four complete kits for a wide variety of cameras and optional cable kits for popular video codec configurations:

Kit Descriptions:

RC1-Sx™	General purpose interface (Canon, Elmo & Sony)	Page 2
RC1-SB™	Sony BRC-300 ¹	Page 3
RC1-SP™	Polycom® Powercam™	Page 4
RC1-ST™	Tandberg® Wave-II™ ²	Page 5

Cable Sets:

RC1-Sx™	General purpose cables	Page 6
RC1-SB™	Sony BRC-300 ¹	Page 6
RC1-SP™	Polycom® Powercam™	Page 6
RC1-ST™	Tandberg® Wave-II™ ²	Page 6

Optional Codec-Specific Cables:

Polycom	Codec Selection Guide	Page 7
Tandberg	Codec Selection Guide	Page 7

¹ Sony BRC-300 currently supports S-Video, power & control up to 100 feet on a single Cat5

² Tandberg Wave-II™ camera control loop limited to manufacturers specification

General Purpose Kit

SCT part number:

RC1-Sx™

Included in this package are:

1. **Mounting Bracket:** This bracket mounts to a standard 2-gang wall box for clean, convenient mounting of the camera. Typical electrical boxes would be:
 - a. new construction 2-gang switch box
 - b. "mud" box
 - c. old work (retrofit) boxes.
2. **Mounting Screw:** A thumb screw is provided for attaching the camera to the mounting bracket shelf.
3. **Interface Modules:** This pair of interfaces provides S-Video, power and control (RX, TX, GND & IR) for the camera. One small electronics enclosure is required at the rack or head end and a second module is mounted to the back of the camera mounting plate, housed in the 2-gang box.
4. **Power Supply:** The included 30VDC power supply is designed to operate a camera up to 300' from the head-end while providing clean, regulated power for safe operation of the camera. 30 Volts from the head end power supply is regulated to 12 VDC at the camera for clean, reliable operation.
5. **Molded Cables:** Two molded cables are included in this kit.
 - a. Sx001 Camera cable is a molded 8-Pin mini DIN plug (White) for the camera mount electronics that breaks out to a molded S-Video plug (Yellow), 2-Pin power plug (Black, regulated 12V DC) and 8-Pin mini DIN for control (Black).
 - b. Sx003 Head end cable is a molded 8-Pin mini DIN plug (Blue) for the head end electronics that breaks out to a molded S-Video jack (Yellow) and a molded BD9 (Black) for remote control.

Simple RC1-Sx™ System Diagram

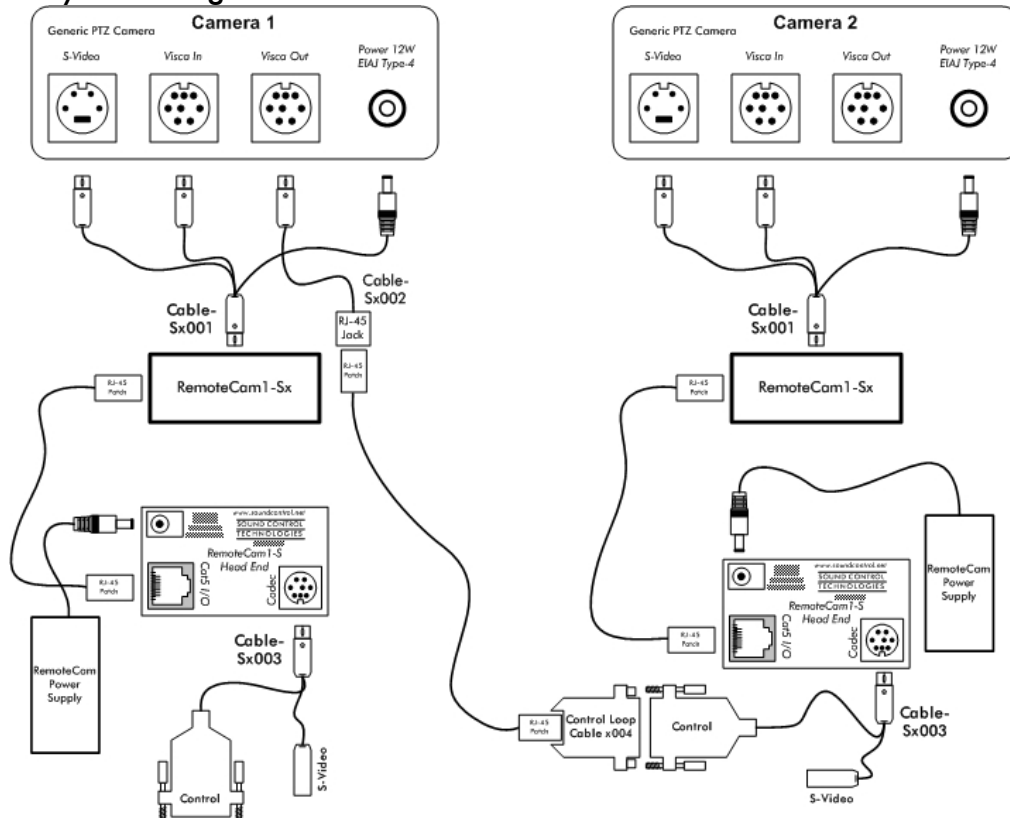

Sony BRC-300™³

SCT part number:

RC1-SB™

Included in this package are:

1. **Mounting Bracket:** This bracket mounts to a standard 3-gang wall box for clean, convenient mounting of the camera. Typical electrical boxes would be:
 - a. new construction 3-gang switch box
 - b. old work (retrofit) boxes.
2. **Mounting Screw:** A thumb screw is provided for attaching the camera to the mounting bracket shelf.
3. **Interface Modules:** This pair of interfaces provides S-Video, power and control (RX, TX, GND & IR) for the camera. One small electronics enclosure is required at the rack or head end and a second module is mounted to the back of the camera mounting plate, housed in the 3-gang box.
4. **Power Supply:** The included 30VDC power supply is designed to operate a camera up to 100' from the head-end while providing clean, regulated power for safe operation of the camera. 30 Volts from the head end power supply is regulated to 12 VDC at the camera for clean, reliable operation.
5. **Molded Cables:** Two molded cables are included in this kit.
 - a. Sx001 Camera cable is a molded 8-Pin mini DIN plug (White) for the camera mount electronics that breaks out to a molded S-Video plug (Yellow), 2-Pin power plug (Black, regulated 12V DC) and 8-Pin mini DIN for control (Black).
 - b. Sx003 Head end cable is a molded 8-Pin mini DIN plug (Blue) for the head end electronics that breaks out to a molded S-Video jack (Yellow) and a molded BD9 (Black) for remote control.

Simple RC1-SB™ System Diagram

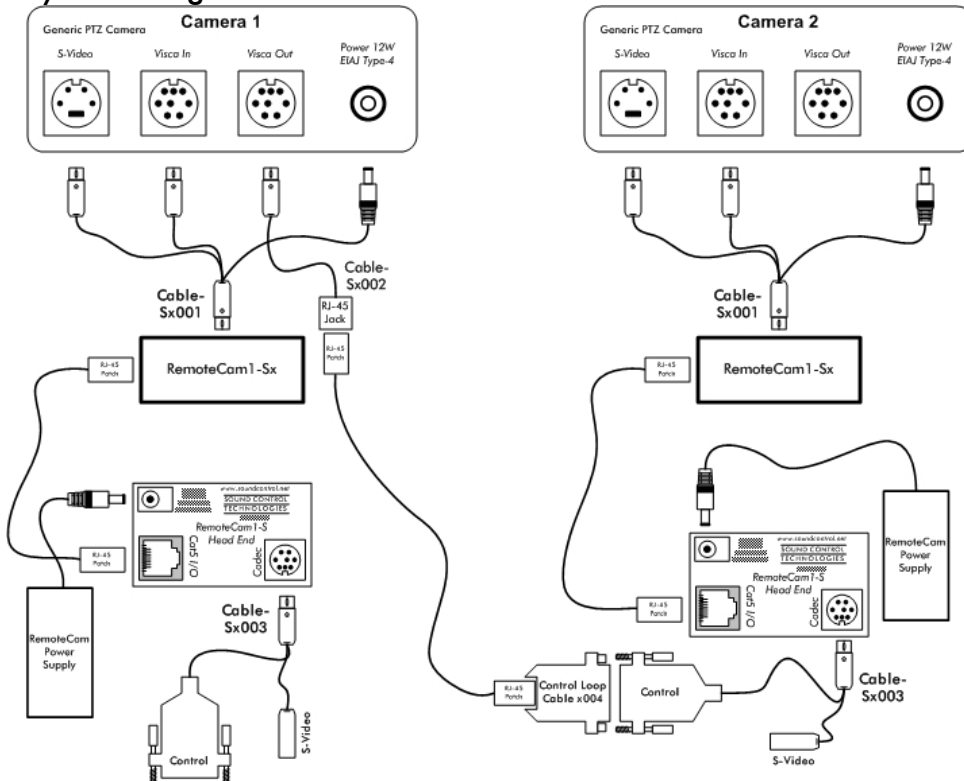

³ Sony BRC-300 currently supports S-Video, power & control up to 100 feet on a single Cat5

Polycom® Powercam™

SCT part number:

RC1-SP™

Included in this package are:

1. **Mounting Bracket:** This bracket mounts to a standard 2-gang wall box for clean, convenient mounting of the camera. Typical electrical boxes would be:
 - a. new construction 2-gang switch box
 - b. "mud" box
 - c. old work (retrofit) boxes.
2. **Mounting Screw:** A thumb screw is provided for attaching the camera to the mounting bracket shelf.
3. **Interface Modules:** This pair of interfaces provides S-Video, power and control (RX, TX, GND & IR) for the camera. One small electronics enclosure is required at the rack or head end and a second module is mounted to the back of the camera mounting plate, housed in the 2-gang box.
4. **Power Supply:** The included 30VDC power supply is designed to operate a camera up to 300' from the head-end while providing clean, regulated power for safe operation of the camera. 30 Volts from the head end power supply is regulated to 12 VDC at the camera for clean, reliable operation.
5. **Molded Cables:** Two molded cables are included in this kit.
 - a. SP001 Camera cable is a molded 8-Pin mini DIN cable for the camera mount electronics that connects S-Video, power and control to the Powercam™.
 - b. Sx003 Head end cable is a molded 8-Pin mini DIN plug (Blue) for the head end electronics that breaks out to a molded S-Video jack (Yellow) and a molded BD9 (Black) for remote control.

Simple RC1-SP™ System Diagram

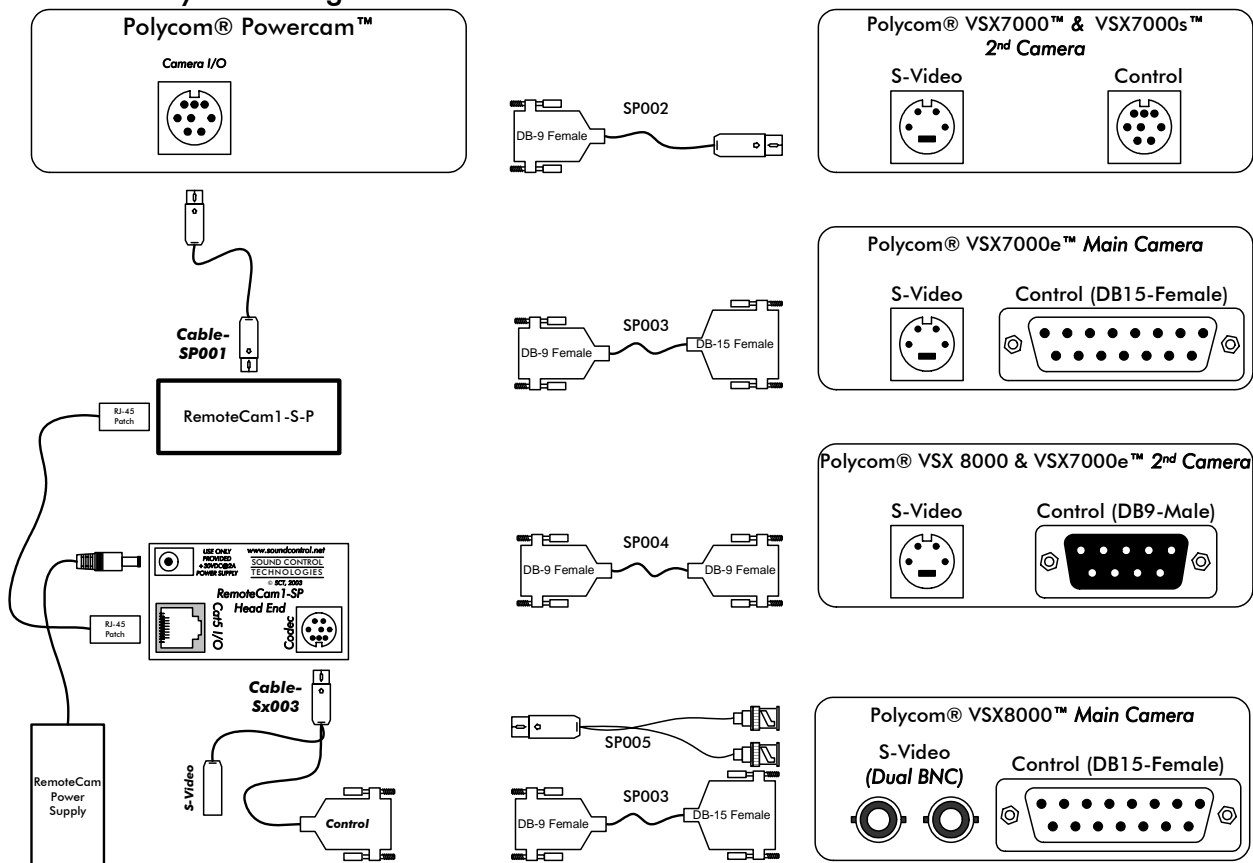

Included in this package are:

1. **Mounting Bracket:** This bracket mounts to a standard 2-gang wall box for clean, convenient mounting of the camera. Typical electrical boxes would be:
 - a. new construction 2-gang switch box
 - b. "mud" box
 - c. old work (retrofit) boxes.
2. **Mounting Screw:** A thumb screw is provided for attaching the camera to the mounting bracket shelf.
3. **Interface Modules:** This pair of interfaces provides S-Video, power and control (RX, TX, GND & IR) control for the camera. One small electronics enclosure is required at the rack or head end and a second module is mounted to the back of the camera mounting plate, housed in the 2-gang box.
4. **Power Supply:** The included 30VDC power supply is designed to operate a camera up to 300' from the head-end while providing clean, regulated power for safe operation of the camera. 30 Volts from the head end power supply is regulated to 12 VDC at the camera for clean, reliable operation.
5. **Molded Cables:** Two molded cables are included in this kit.
 - a. ST001 Camera cable is a molded 8-Pin mini DIN plug (White) for the camera mount electronics that breaks out to a molded S-Video plug (Yellow), 2-Pin power plug (Black, regulated 12V DC) and RJ-45 for control (Black).
 - b. Sx003 Head end cable is a molded 8-Pin mini DIN plug (Blue) for the head end electronics that breaks out to a molded S-Video jack (Yellow) and a molded BD9 (Black) for remote control.

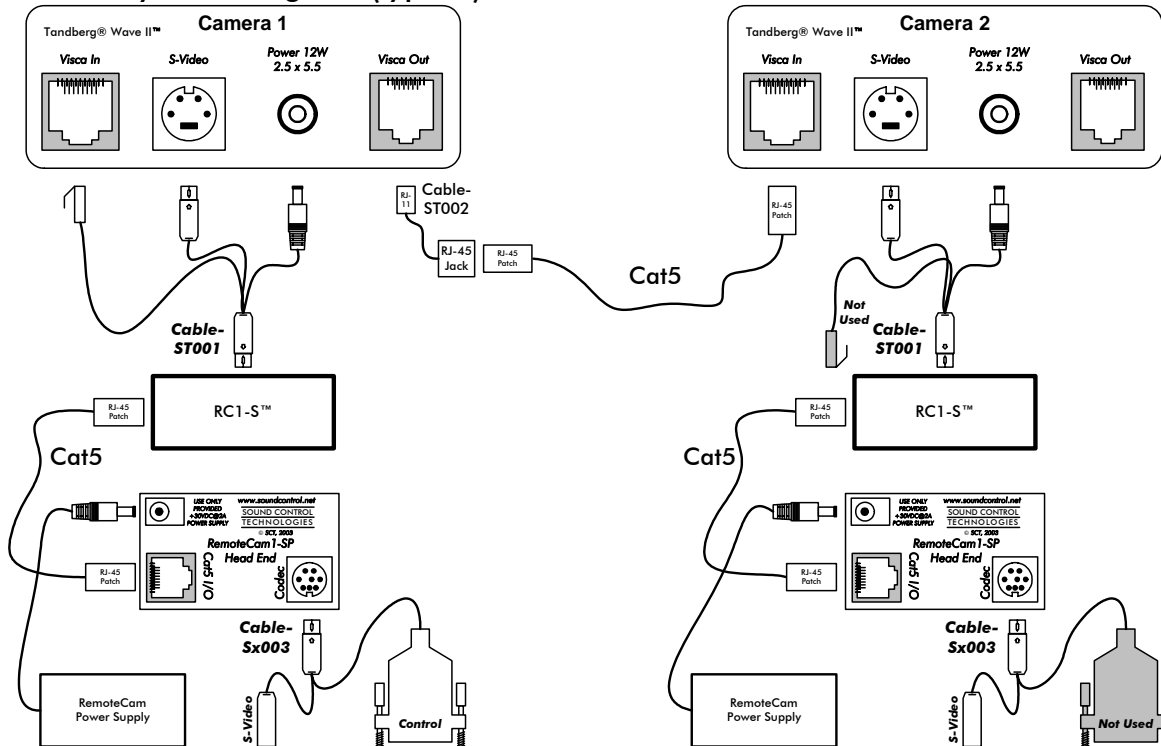

Simple RC1-ST™ System Diagram (typical)





⁴ Tandberg Wave-II™ camera control loop limited to manufacturers specification

Camera Cables



RC1-Sx™ & RC1-SB™ Kit Cables

<p>Sx001 Camera Cable 4-Pin mini DIN S-Video Plug (Yellow) 8-Pin mini DIN Control (Black) 2-Pin 12 VDC Power 8-Pin mini DIN Unified (White)</p>	
<p>Sx003 Head End Cable (standard with all kits) 4-Pin mini DIN S-Video Jack (Yellow) DB9 Control (Black) 8-Pin mini DIN Unified (Blue)</p>	



Optional GPC-1 Camera Control Loop Cable Kit for RC1-Sx™ & RC1-SB™

<p>Sx002 Camera Control Loop Cable 8-Pin mini DIN Control (Red) 8-Pin RJ-45 Jack (Black)</p>	
<p>Sx004 Head End Control Loop DB9 Control (Black) 8-Pin RJ-45 Jack (Black)</p>	

Included RC1-SP™ Kit Cables

<p>SP001 Camera Cable 8-Pin mini DIN Camera connection (Black) 8-Pin mini DIN Unified (Black)</p>	
<p>Sx003 Head End Cable (standard with all kits) 4-Pin mini DIN S-Video Jack (Yellow) DB9 Control (Black) 8-Pin mini DIN Unified (Blue)</p>	

Included RC1-ST™ Kit Cables



<p>ST001 Wave-II Camera Cable 4-Pin mini DIN S-Video Plug (Yellow) 8-Pin RJ-45 Control (Black) 2-Pin 12 VDC Power 8-Pin mini DIN Unified (White)</p>	
<p>Sx003 Head End Cable (standard with all kits) 4-Pin mini DIN S-Video Jack (Yellow) DB9 Control (Black) 8-Pin mini DIN Unified (Blue)</p>	

Optional Codec-Specific Cables:

Optional Polycom Codec-Specific Interface Cable Kits

Codec & Port	VSX-7000 2nd Camera	VSX-7000s 2nd Camera	VSX-7000e Main Camera	VSX-8000 Main Camera	VSX-8000 2nd Camera	VSX-7000e 2nd Camera
Control	SP002	SP002	SP003	SP003	SP004	SP004
Video	Sx005	Sx005	Sx005	SP005	Sx005	Sx005
Cable Set	VSX-1	VSX-1	VSX-2	VSX-3	VSX-4	VSX-4

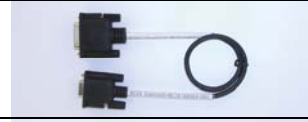

Optional Polycom Codec-Specific Interface Cables

SP002 VSX-7000 2nd Camera VSX-7000s 2nd Camera DB9 to 8-Pin mini DIN	
SP003 VSX-7000e Main Camera VSX-8000 Main Camera DB9 to DB-15	
SP004 VSX-8000 2nd Camera VSX-7000e 2nd Camera DB9 to DB9	
SP005 VSX-8000 Main Camera 4-Pin mini DIN to x2 BNC	
Sx005 S-Video patch cable 4-Pin mini DIN to 4-Pin mini DIN	

Optional Tandberg Codec-Specific Interface Cable Kits

Codec & Port	770, 880, 990 2nd Camera	3000MXP Main Camera	3000MXP 2nd Camera	6000MXP Main Camera	6000MXP 2nd Camera
Control	ST003	ST004		ST003	
Video	Sx005		Sx005	Sx005	Sx005
Control Loop			ST002		ST002
Cable Set	MXP-1	MXP-3	MXP-2	MXP-1	MXP-2

Optional Tandberg Codec-Specific Interface Cables

ST002 Camera Control Loop Cable 6-Pin RJ-11 Plug Control Loop (Red) 8-Pin RJ-45 Control Jack (Black)	
ST003 Straight thru serial cable DB9 to DB9	
ST004 3000MXP Main Camera Unified S-Video & Control 8-Pin mini DIN to DB9 Used in place of Sx005	

Technical Specifications:

Technical specifications are subject to change. This information applies to a product under development; specifications are subject to change without notice.

Camera Interface:

Unified Jack:	8-Pin mini DIN (break out cables are version specific, supplied)
Video Input:	S-Video
Control	RS-232 I/O
Power Output	RX, TX, GND & IR +12VDC @ 1.3A Max

Head-End Interface:

Unified Jack:	8-Pin mini DIN (break out cable supplied)
Video Output:	S-Video
Connector	4-Pin mini DIN Jack
Control:	RS-232 I/O & IR Out
Connector	DB-9 Female (RX, TX, GND) & IR Out
Power Input:	+30VDC @ 2.0A Max
Connector	2 Pin Circular 5.5 x 2.5mm

Power Requirements: +30VDC, 2.0A
External Universal AC Input Supply Included

Size: H 0.75", W 1.5", D 2.5"
Weight: 1.0 lbs.

For the original equipment supplier, custom configurations of the *Series II ASP-8x8 Audio Matrix™*, Acoustic Echo Cancellation, Microphone Mixers, Camera Control Products and other SCT equipment are available. Please contact SCT for details on pricing and availability.

Please note that many other cameras, cables and codecs may be supported. Please contact SCT or your local representative for more information.

All Trademarks are the property of their respective owners. No claim is made to any marks other than those expressly the property of Sound Control Technologies, Inc.