

Systems Overview

Sound Control Technologies' full duplex, multiple zone VOICELIFT™ voice enhancement systems and TELEPLEX™ full duplex teleconferencing systems combine several patented acoustic cancellation principles to achieve proper gain before feedback, providing intelligible, conversational level audio throughout the covered areas.

These principles include:

- A: Acoustic cancellation by wiring groups of microphones and/or speakers within the same audio zone out of phase with respect to each other.
- B: Enhancing the acoustic cancellation gain by accurately locating matched pairs of microphones and/or speakers in the ceiling.
- C: Further enhancing the acoustic cancellation by electronically balancing matched pairs of microphones.
- D: Eliminating intrusive feedback frequencies through 5 independent sequential, tunable notch filters per zone.
- E: Feeding each acoustical zone from other zones with sufficient signal delay to create a sense of "directionality" from one end of a room to the other. (Haas Effect)
- F: Providing proper signal level scaling at summing points within the system matrix to coordinate with the geometry of the signal sources and destinations.

The drawings below illustrate the basic acoustic cancellation process used in typical ceiling mounted VOICELIFT™ and TELEPLEX™ systems.

Speaker Sound Returning to Microphone

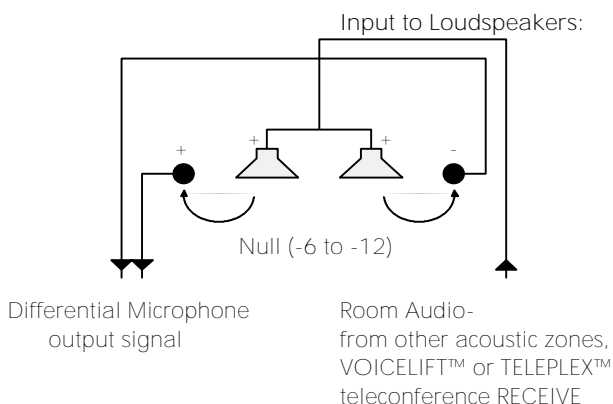

Note: Out-of-Phase microphones precisely located equidistant from speakers cause null, providing 6 to 12dB additional headroom

Room Sound Entering Microphones

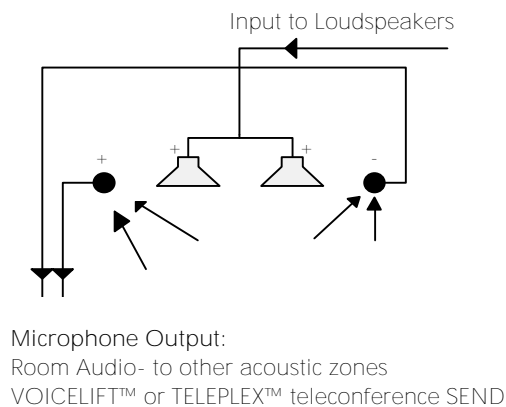

Note: Various paths and time(signal) delays negate out-of phase microphone cancellation for acoustic signals originating in a room

Voicelift Signal Flow

The drawing below represents a two zone VOICELIFT™ system with the microphones of each zone routed, via the matrix (VF-1 Matrix Card frame), to the speakers in other zones. Different gain into each zone may also be set within the matrix. A signal delay line is used before the amplified output of each zone to take advantage of Hass Effect on directionality between zones in the system.

Larger multi zoned systems would also take advantage of the gain structuring capabilities (providing proper level attenuation to correspond with physical distances in a room) and signal routing flexibilities of the VF-1 Matrix card frame.

Typical VOICELIFT™ Voice Enhancement Signal Flow

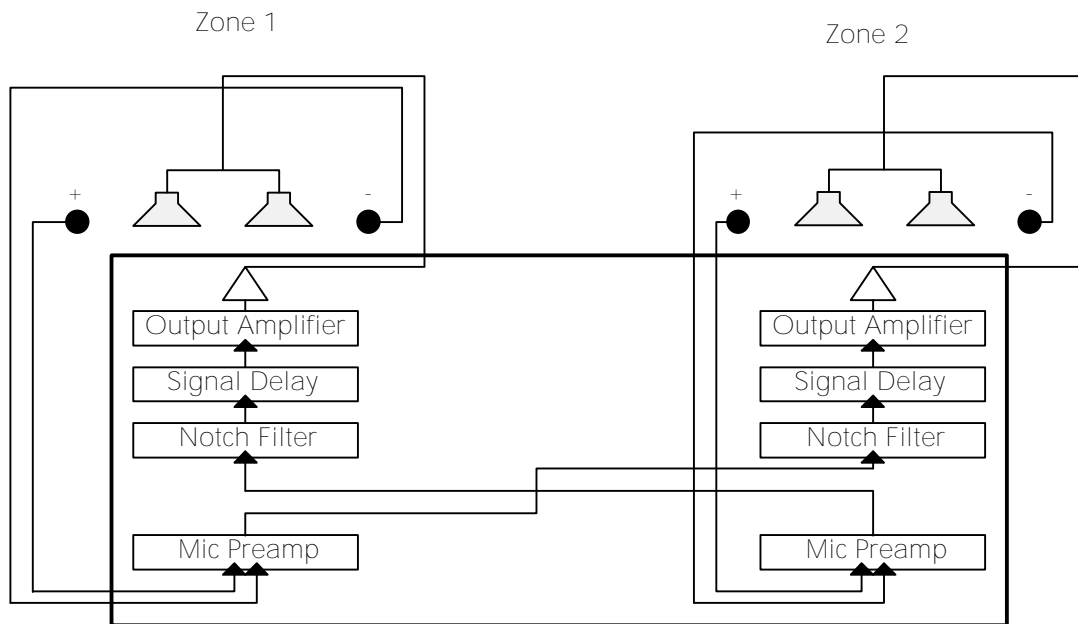

VF-1 Matrix Card frame

Teleconference Signal Flow

Room audio support for either audio or video teleconferences can be accomplished with either:

- * VF-1 Matrix Card frame (usually also encompassing VOICELIFT™),
- * AudioLink™, where ceiling microphones will be the primary pick-up,
- * AUDIOLINK Plus™, for small table top microphone systems (up to six microphones),
- * Custom sound system,

used in conjunction with the AVT-24™ audio and video teleconferencing interface to form a full duplex audio conferencing system. The diagram below represents a simplified conferencing system.

Typical Teleconferencing System Signal Flow

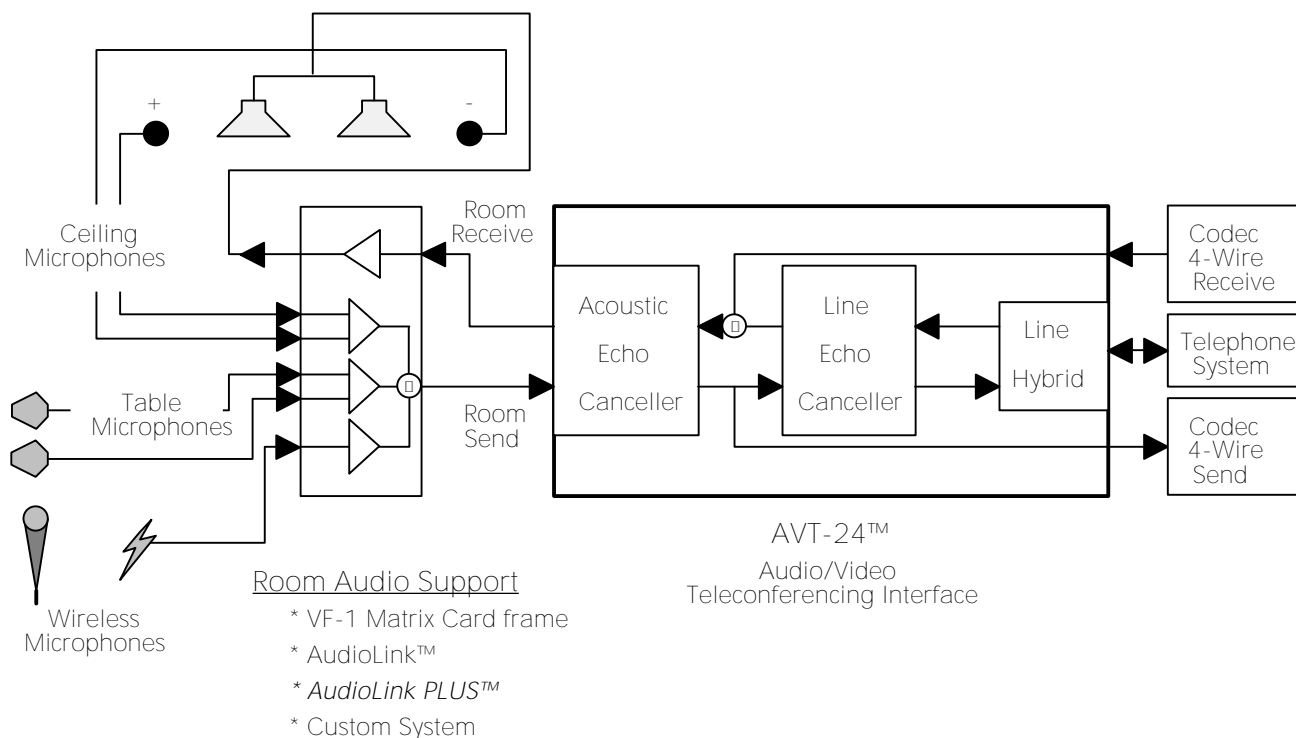

Articulation Index A numerical value (0 to 1.0) of speech intelligibility, derived from an analysis of background sound, expected speech effort and the acoustical qualities of an area and its components.

dB Decibels measured on the "A" scale of a sound level meter. This is the most frequently used decibel scale, and measures "perceived" loudness by giving more weight to high frequency sounds which seem louder to people than the same intensity of low frequency sounds. This scale is preferred for speech privacy measurements because it corresponds closely to the sensitivity of the ear. Like the ear, it virtually ignores low frequency sound, but responds accurately to those of normal speech.

Decibel (dB) The basic unit of sound level. A ratio that denotes the intensity of one sound and a reference sound. 0.dB is generally the threshold of audibility. Over 100 dB is usually painful. Measurement of dB levels are made on a sound level meter at specific frequencies. A rise of ten decibels is perceived by the human ear as a doubling of loudness.

Echo Canceller A device which samples an audio input and removes any repetitive remnant of that signal from the audio output to cancel line echo or room feedback.

Full Duplex The ability to have simultaneous, bi-directional communication.

Hertz The unit of frequency. One Hertz equals one cycle per second. The frequency of the human voice can range from 100 to 10,000 Hz. Intelligible speech is between 400 and 2000 Hz.

Hybrid A device used to interface a standard 2-wire telephone circuit to a standard 4-wire audio system. Components may include transformers, op-amps and DSP chips.

Noise Criteria Curves A curve that describes sound levels that are acceptable over a range of frequencies for a specific building function. The ear is less sensitive to low-frequency sound, so the permissible sound levels at such frequencies can be relatively high without causing problems.

Noise Reduction Coefficient (NRC) A single-number rating that establishes the degree of sound absorption of a product or system. The NRC is a good means of comparing the performance characteristics of similar products. A panel with an NRC of 80 means that the panel will absorb 80% of the sound that hits it.

Sabin A measure of sound absorption, equivalent to 1 sq ft of a completely absorbing substance.

Sound Sound is a vibration in an elastic medium. Its production requires a source and a path; it travels to a receiver, usually the human ear. Sound travels by three paths: direct, reflected and diffracted.

Speech Privacy Freedom from any distraction that might be created by a conversation in a nearby work zone. With normal speech privacy, a person may hear fragments of a conversation, but the words will neither be loud enough, nor sufficiently intelligible to be disturbing. Confidential speech privacy means that the sense of the conversation is unintelligible.