

INDEX OF TOPICS:

- I. WIRING THE *SERIES II* AVT-24™
AUDIO LEVELS
- II. ON-SITE SET-UP
 - A. 4 WIRE SET-UP
 - B. 2 WIRE SET-UP
 - C. INPUT HIGHPASS FILTER
- III. CONTROLLING THE *SERIES II* AVT-24™

I. WIRING THE *SERIES II* AVT-24™

All audio connections to the *Series II* AVT-24™ are made to the rear of the unit via removable polarized "captive-wire" connectors and are clearly marked.

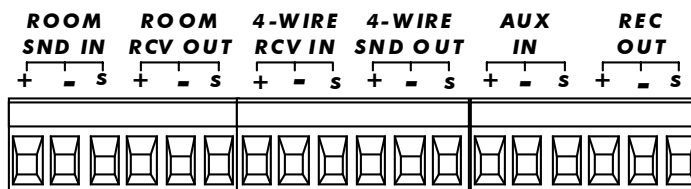

The *Series II* AVT-24™ requires a standard analog telephone line or voice quality (high quality) analog extension from an "in-house" telephone system. The main telephone line connects to the RJ-11 modular connector labeled "Line". For dialing and ringing of incoming calls, a telephone may be connected to the RJ-11 modular connector labeled "Phone".

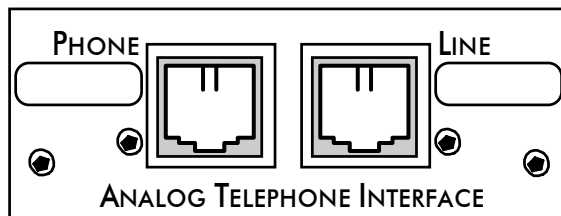

When used in conjunction with SCT Systems, all set up, (including room notching procedures for VOICELIFT™ Systems) wiring checkout and microphone balancing procedures must be thoroughly completed prior to *Series II* AVT-24™ start up.

Rear view of the *Series II* AVT-24™ (Fig. 1)

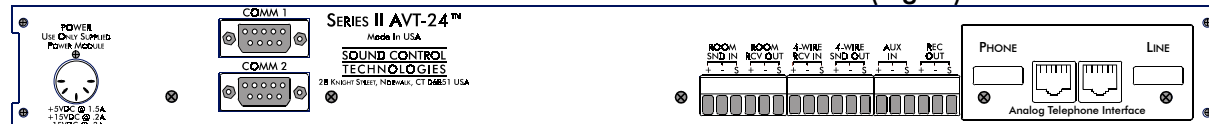

Audio Levels

All line level audio inputs to the Series II AVT-24™, ("ROOM SND. IN", "4-WIRE RCV. IN" and "AUX IN") are designed for a nominal -6.8 dBm (1V peak to peak) signal.

FOR AUDIOLINK™ and AUDIOLINK PLUS™ SYSTEMS:

REAR VIEW AUDIOLINK (Fig 2)

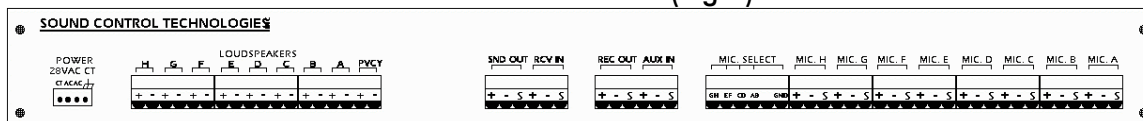

REAR VIEW AUDIOLINK PLUS™ (Fig 3)

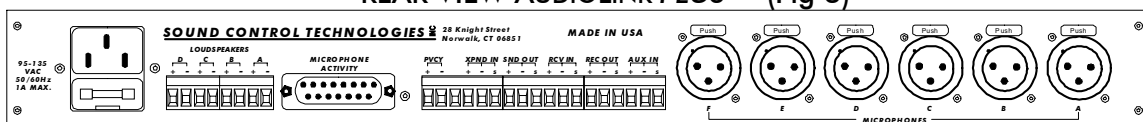

Interfacing the AUDIOLINK, AUDIOLINK PLUS™ or ASP Family of products for microphone and loudspeaker support is done through "Room Rcv. Out" and "Room Send In" on the Series II AVT-24™.

"Room Rcv. Out" on the Series II AVT-24™ connects to "RCV IN" on the AUDIOLINK™ or AUDIOLINK PLUS™ for the distant party's signal to reach the loudspeakers.

The microphone signal from the AUDIOLINK™ or AUDIOLINK PLUS™ is "SND OUT". This connects to "Room Snd In" on the Series II AVT-24™

Pin-out instructions for customized MATRIX Systems are included in the SCT System Documentation Manual customized by SCT and supplied for that system.

During a conference, only 2WRCV or 4WRCV should be adjusted. Other level adjustments may require system retraining.

The AVT series of products have a wide range of level and system parameters that can be adjusted to optimize the product in a wide range of applications. Once these parameters have been adjusted they can be stored in non-volatile memory for long-term system stability.

To "retain" or store the revised setting:

1. Scroll to **MODE:**
PUSH ON TO SAVE
2. Press "ON" ALL system parameters will be stored to non-volatile memory.

Please note that settings changed via the serial port must be stored to non-volatile memory using the NVSAVE=1 command.

II. ON-SITE FRONT PANEL SET-UP: (FOR SERIAL PORT CONTROL SEE PAGE 8)

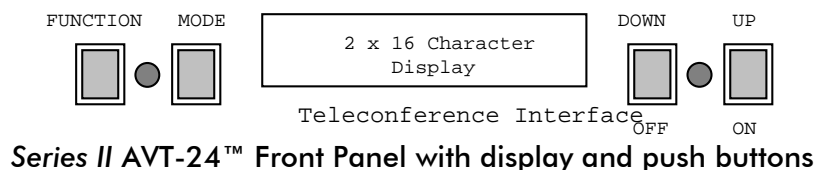

Successive pushes of the MODE button will scroll through the following options on the LCD display:

Step	Line 1	Line 2	Options
1	Mode:	2-WIRE = OFF	ON / OFF
2	Mode:	2-WIRE PVC = OFF	ON / OFF
3	Mode:	4-WIRE = OFF	ON / OFF
4	Mode:	4-WIRE PVC = OFF	ON / OFF
5	Mode:	PUSH ON TO TRAIN	TRAIN SYSTEM (3 SEC)
6	Mode:	PUSH ON TO SAVE	SAVE SYSTEM SETTINGS
7	Mode:	4W->2W PVC = OFF	ON / OFF
8	Mode:	2W->4W PVC = OFF	ON / OFF
9	Mode:	OFF FOR DEFAULTS	FACTORY DEFAULTS
10	Mode:	PWR ON = 4W OFF	POWER ON 4W ON/OFF
11	Mode:	RS FILTR = 120Hz	120/250/500/750
12	Mode:	4WSND MUTE = OFF	ON / OFF
13	Mode:	LEC BYPASS = OFF	TEMPORARY LEC BYPASS
14	Mode:	AEC BYPASS = OFF	TEMPORARY AEC BYPASS
15	Mode:	AEC SIZE = LONG	SHORT / LONG
16	Mode:	AUTO-DISC = OFF	ON / OFF

Successive pushes of the FUNCTION button will scroll through the following options on the LCD display:

Step	Line 1	Line 2	Options
1	FUNCTION:	2W RCV : 0.0 dB	±6 dB in 1.5 dB Steps
2	FUNCTION:	2W SND : 0.0 dB	+12/-6 dB in 1.5 dB Steps
3	FUNCTION:	2W A/D : 0.0 dB	±6 dB in 1.5 dB Steps
4	FUNCTION:	4W RCV : 0.0 dB	±6 dB in 1.5 dB Steps
5	FUNCTION:	4W SND : 0.0 dB	±6 dB in 1.5 dB Steps
6	FUNCTION:	4W A/D : 0.0 dB	±6 dB in 1.5 dB Steps
7	FUNCTION:	RM RCV : 0.0 dB	±6 dB in 1.5 dB Steps
8	FUNCTION:	RM SND : 0.0 dB	±6 dB in 1.5 dB Steps
9	FUNCTION:	RECORD : 0.0 dB	±6 dB in 1.5 dB Steps
10	FUNCTION:	AUX-IN : 0.0 dB	±6 dB in 1.5 dB Steps
11	FUNCTION:	AUX>SND: 0.0 dB	±6 dB in 1.5 dB Steps
12	FUNCTION:	AUX>RM : 0.0 dB	±6 dB in 1.5 dB Steps
13	FUNCTION:	AUX>REC: 0.0 dB	±6 dB in 1.5 dB Steps
14	FUNCTION:	4>2 BRG: 0.0 dB	±6 dB in 1.5 dB Steps
15	FUNCTION:	2>2 BRG: 0.0 dB	±6 dB in 1.5 dB Steps

On "power up" there will be several sign-on messages:

```
AVT24 BIOS V3.06  
SELF TEST: XXX
```

```
AVT24 BIOS V3.06  
SELF TEST PASSED
```

```
SOUND CONTROL  
TECHNOLOGIES
```

```
SOUND CONTROL  
AVT-24 VER:3.14
```

```
SOUND CONTROL  
-SYSTEM STARTUP-
```

The SCT AVT-24™ & AVT-44™ series of DSP signal processors are serial port firmware upgradeable.

The VER(sion) number reflects the firmware level of the unit.

To upgrade system firmware contact your system installer or SCT.

then the "standby" display appears

```
AVT-24 SERIES II  
STATUS: OK v0.33
```

```
SET UP SEQUENCE
```

Initializing and Training

The Series II AVT-24™ echo cancellers are fully adaptive. "Initialization" and "Training" brings the system to optimization for the installed environment, accelerating the normal adaptive process. Once the training has been initialized, the system will then continuously adapt to normal changes, movement or similar transient conditions in the room.

To properly initialize the adaptive echo canceller for the installed environment, it is necessary to cycle through the "TRAIN" routines for **both 2 wire and 4 wire modes**.

A. 4 WIRE INITIALIZATION:

- | <u>STEP (MODE)</u> | <u>ACTION</u> |
|--------------------|---|
| 1. Scroll to | 4-WIRE = OFF |
| 2. Press "ON", | the 4 wire LED will light |
| 3. Scroll to | PUSH ON TO TRAIN |
| 4. Press "ON", | training sound will be heard for 3-4 seconds, then stop |
| 5. Scroll to | 4-WIRE = ON |
| 6. Press "OFF", | the 4 wire LED will go off |

B. 2 WIRE INITIALIZATION:

Using the system telephone handset place a call. Verify that call is connected and an acceptable quality line has been established, then:

- | <u>STEP (MODE)</u> | <u>ACTION</u> |
|--------------------|--|
| 1. Scroll to | 2-WIRE = OFF |
| 2. Press "ON", | the 2 wire LED will light. The call is now on the "SYSTEM".
The far party will probably hear a pronounced echo. |
| 3. Scroll to | PUSH ON TO TRAIN |
| 4. Press "ON" | training sound will be heard for 3-4 seconds, then stop. |
| 5. Scroll to | 2-WIRE = ON |
| 6. Press "OFF", | the 2 wire LED will go off |

This training process is generally only required at initial system set-up or if significant changes are made to the room. Retraining, (Step 3 in either mode) may be done at any time.

After a change in the general system level settings, a new "training" should be done. A "starting point" has now been established for the echo cancellers.

Training the Series II AVT-24™ & AVT-44™ from the front panel push buttons automatically saves the new echo canceller training to non-volatile memory. Training these devices via the serial port will update the echo canceller model for the current call connection but DOES NOT save the new training to non-volatile memory.

Since a model of the room and line has been created in coefficient memory, this model is essentially the impulse response of the room/line. Reviewing this data can show the effectiveness of acoustic treatment and provide an indication of the relative intelligibility of the teleconference room.

Coefficient values can range from ± 1.0 , although proper set up should produce coefficients within ± 0.5 at initial burst, decaying steadily over the next few hundred milliseconds. High initial coefficients generally relates to inadequate room physical acoustic treatment.

The following diagram is a plot of typical amplitude and time coefficient values of the room.

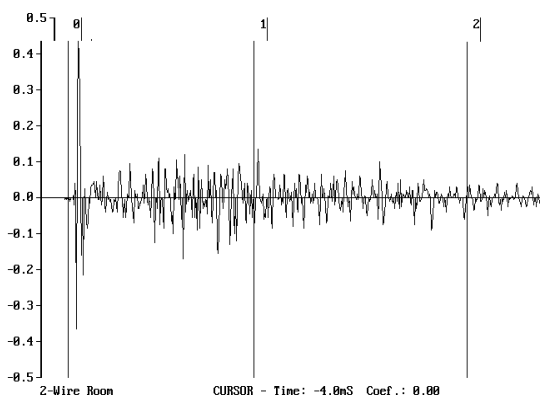

Figure 3 Plot of Room Echo Canceller coefficients

C. INPUT HIGHPASS FILTER:

To help compensate for higher than desired ambient noise or reflective acoustic room conditions, a programmable Input Highpass (Noise Reduction) Filter has been provided:

- | <u>STEP (MODE)</u> | <u>ACTION</u> |
|--------------------|---|
| 1. Scroll to | RS FILTR = 120Hz |
| 2. Press "UP", | the filter roll-off will change. Filter selections are 120, 250, 500 and 750 Hz. A re-train is required after changing the RS-FILTER. |

III. CONTROLLING THE *SERIES II AVT-24™*

The *Series II AVT-24* has been designed to accept instructions from remote locations via RS-232 commands through 2 rear serial ports (COM 1, COM 2).

SCT's RT-3 wired remote RS-232 control unit for the *Series II AVT-24™* telephone interface is factory programmed for the following functions with an LCD screen display:

- * ON/OFF transfer of the teleconference call
- * Stepped VOLUME CONTROL - UP/DOWN of the RECEIVE sound level in the room
- * PRIVACY
- * Last call REDIAL
- * KEY PAD dialing

1. Systems using the SCT RT-3 interface through the COM-1 Serial Port can raise or lower the ROOM volume (2WRCV) from the RT-3 keypad. Each step UP or DOWN is 1½ dB. (See the RT-3 Instruction Sheet)

The RT-3 is wired from its 6 pin RJ-11 connectors to the *Series II AVT-24™* COM-1 port.

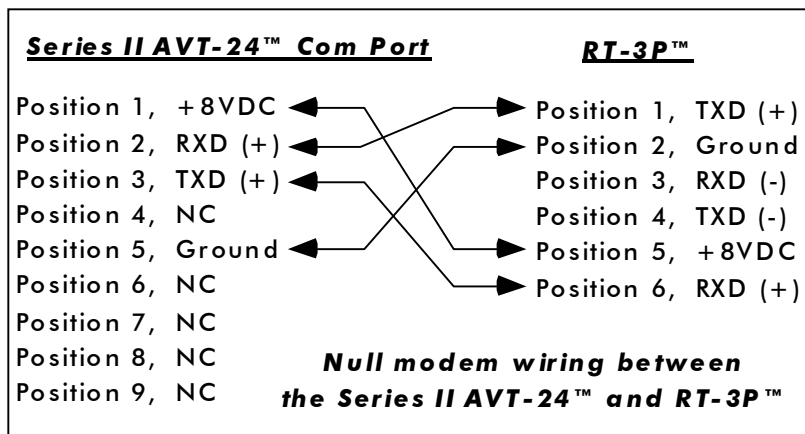

2. Systems being controlled by integrated remote control systems can control volume SEND or RECEIVE through COM 1 or COM 2.

Series II AVT-24™ Rear View

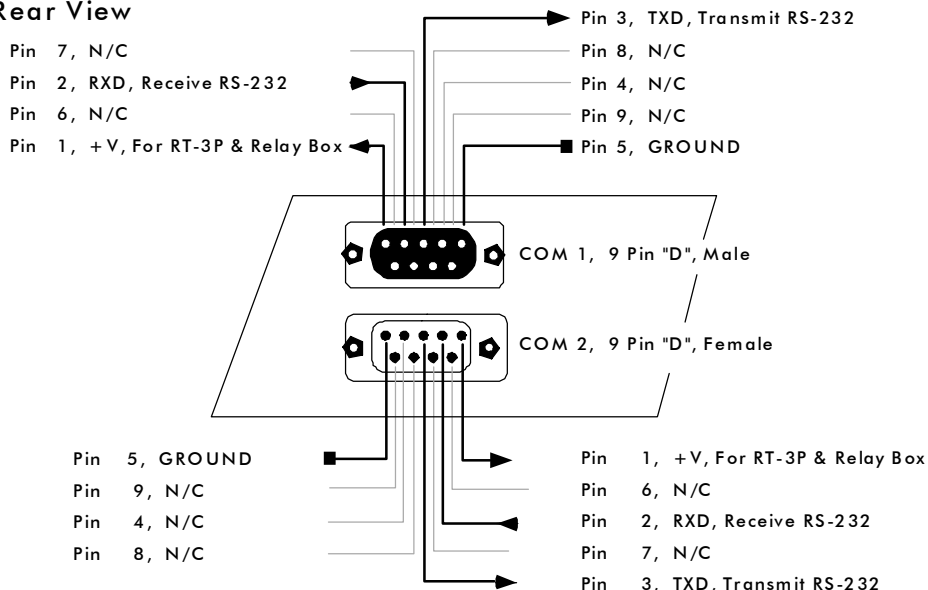

Protocol for COM 1 or COM 2 follows.

Baud Rate:	9600/19,200	8 = +6.0 dB
Word Length:	8 bits	7 = +4.5 dB
Parity:	None	6 = +3.0 dB
Stop Bit:	1	5 = +1.5 dB
		4 = 0 dB
		3 = -1.5 dB
		2 = -3.0 dB
		1 = -4.5 dB
		0 = -6.0 dB

Note: "X" values are 0-8 software levels in 1.5 dB steps.

SOUND CONTROL TECHNOLOGIES

Series II AVT-24™ INSTALLATION MANUAL AUDIO/VIDEO TELECONFERENCING INTERFACE BIOS 3.06/ Host 3.15/ DSP 0.33

1: STATUS= E Screen Display	PRVCY=3 Un-Mutes 2W SEND signal
STATUS=	
DEVICE=AVT-24 Device label	PRVCY=4 Mutes 4W SEND signal
VERSION=3.12 Host Version	PRVCY=5 Un-Mutes 4W SEND signal
DSPVERSION=003030 DSP Version	
2WIRE=0 Two Wire Status	PRVCY=6 Mutes 4WRCV>2WSND
4WIRE=0 Four Wire Status	PRVCY=7 Un-Mutes 4WRCV>2WSND
PRVCY=0 Privacy Status	
AA=0 Auto Answer Status	PRVCY=8 Mutes 2WRCV>4WSND
2WRCV=4 2W Receive Level	PRVCY=9 Un-Mutes 2WRCV>4WSND
2WA/D=4 2W A/D Level	
2WSND=4 2W Send Level	5. AA=(1-9) Rings for AUTO ANSWER
42BRG=4 4WRCV Level to 2WSND	AA=0 No AUTO ANSWER
RMRCV=4 Room Receive Level	
RMSND=4 Room Send Level	6. 2WRCV=X 2 Wire RECEIVE level
4WRCV=4 4W Receive Level	Defaults to "0" after each call
4WA/D=4 4W A/D Level	7. 2WA/D=X 2 Wire RECEIVE level
4WSND=4 4W Send Level	8. 2WSND=X 2 Wire SEND level
24BRG=4 2WRCV Level to 4WSND	
RECRD=4 Record output level	9. 42BRG=X 4WRCV>2WSND level
AUXIN=4 Aux. Input level	
LOCK=0 Lock Front Panel Buttons	10. RMRCV=X ROOM RECEIVE level
REPORT=0 Verbose Serial Port	11. RMSND=X ROOM SEND level
RLYMODE=0 External Relay Box*	
RLYPORT=1 External Relay Box*	12. 4WRCV=X 4 Wire RECEIVE level
COM1=5 9600/19,200	Defaults to "0" after each call
COM2=5 9600/19,200	
AUXREC=4 Aux Level to Record	13. 4WA/D=X 4 Wire RECEIVE level
AUXRM=4 Aux Level to Room	14. 4WSND=X 4 Wire SEND level
AUXSND=4 Aux Level to Send	
PWRON4W=0 Default 4W Mode	15. 24BRG=X 2WRCV>4WSND level
M-MUTE=0 Input Mute	
RSFILTER=2 Input High Pass Filter	16. COM1=5/7 9600/19,200 bps
4WSNDMUTE=0 4W SND Mute	COM2=0/5 OFF/9600 bps
LEC=0 Temporary LEC Bypass	
AEC=0 Temporary AEC Bypass	17. DTMF=0 - 9, *, # Dials 0-9, *, #
AECSIZE=1 170/275 ms. AEC Size	18. TRAIN=x Training for the echo
AECTYPE=0 Future	
AUTODISC=1 Auto 2W Disconnect*	
DELAYMODE=0 **	
DELAYTIME=0 **	
@ Status End	
2. 2WIRE=0/1 2 Wire ON/OFF HOOK	19. SAVE=1 Saves AEC training
3. 4WIRE=0/1 4 Wire ON/OFF	20. NVSAVE=1 Saves user settings & levels
4. PRVCY=0 Un-Mutes ALL SEND signals	21. M-MUTE=1 Mutes "Room Output"
PRVCY=1 Mutes ALL SEND signals	M-MUTE=0 Un-Mutes "Room Out"
PRVCY=2 Mutes 2W SEND signal	22. REBOOT=1 Reboots AVT-24™

NOTE: An incoming call will send an ASCII "Bell" character 07 out of the COM ports as a RING indicator. This can be decoded by a remote control system for external signaling. The RT-3 has an integrated ringer.